

BEFORE YOU BEGIN

安装之前

- Please read these instructions carefully to familiarize yourself with the required tools, materials, and installation sequences. Follow the sections that pertain to your particular installation. This will help you avoid costly mistakes. In addition to proper installation, read all operating and safety instructions.
 - All information in these instructions is based upon the latest product information available at the time of publication. Kohler China reserves the right to make changes in product characteristics, packaging, or availability at any time without notice.
 - These instructions contain important care, cleaning, and warranty information - **please leave instructions for the consumer.**
 - This product complies with
- 请小心参阅本指引。以便熟悉所需工具、材料及安装程序。请遵照适用的章节来安装你的产品。以避免由于安装不当而导致不必要的损失。除了有关正确的安装方法之外，还务请详阅所有操作及安全指引。
 - 本指引所载之一切材料，均以印刷时所有之最新产品情况为基础。科勒中国保留权利随时更改产品特性、包装或供应情况，恕不另行通知。
 - 本指引也包含了有关护理、清洁及保养等重要资料-请交予用户留存。
 - 本产品符合

SPECIFICATIONS

规格说明

Activation	Activated by an infrared sensor. The machine operates automatically.
Dimensions W × H × D	132.8x47.5x80.2mm
Voltage	DC 6V
Sensing distance	7±1cm
Applicable viscosity of soap solution Ambient temperature	1 - 10CPS (mPa.s)
Ambient temperature capacity	1 C - 55 C
Regulating mode	1.6 L
Soap volume dispensed	Press button to adjust the distance
	4-level adjustable

启动方式	红外触发激光，自动感应
外型尺寸 W × H × D	132.8x47.5x80.2mm
电压	DC 6V
感应距离	7±1cm
适用皂液黏度	1 - 10CPS (mPa.s)
环境温度	1 °C - 55 °C
皂瓶容量	1.6L
调节方式	按钮调距
出液量	4档可调

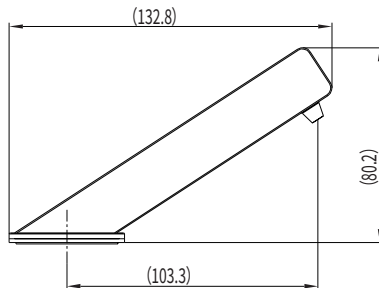
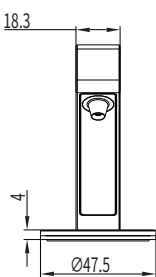

KOHLER CHINA INVESTMENT CO., LTD NO.158, JIANG CHANG SAN ROAD,
JING'AN DISTRICT, SHANGHAI, PRC POST CODE: 200436
科勒(中国)投资有限公司 上海市静安区江场三路158号 邮编: 200436

© Copyright Kohler China Investment Co., Ltd. 2020

© 版权为科勒(中国)投资有限公司所有 2020

BEFORE YOU BEGIN

安装前的注意事项

WARNING: When using electrical products, basic precautions should always be followed, including the following:

DANGER: Risk of electric shock. Connect only to a circuit protected by a Ground-Fault Circuit-Interrupter (GFCI)*.

WARNING: Risk of electric shock. Disconnect the power before servicing.

WARNING: Risk of injury or property damage. Read all instructions thoroughly before beginning installation.

CAUTION: Risk of product damage. This product contains sensitive electronic components. Do not store open containers of chemical or cleaning products near this product. Cleaning rags or sponges must be rinsed with fresh water before storage.

CAUTION: Risk of product damage. Only use foaming hand soap with viscosity between 1 CPS and 20 CPS. Gel soaps and foaming hand soaps not within the CPS range will damage the soap dispenser and void the warranty.

IMPORTANT! Your product may appear different than illustrated. The installation procedure is the same. Consult the specification sheet for rough-in dimensions for your model requirements.

Follow all local plumbing and electrical codes.

CAUTION: Risk of product damage. Only use foaming hand soap with viscosity between 1 CPS and 20 CPS. Gel soaps and foaming hand soaps not within the CPS range will damage the soap dispenser and void the warranty.

警告: 使用电气产品时, 必须始终采取下列基本预防措施:

危险: 有触电危险。只能连接至有接地故障电路断路器(GFCI)*保护的电路。

危险: 有触电危险。维修前需断开电源。

警告: 有受伤或财产损失的危险。开始安装之前, 请充分阅读所有说明。

注意: 产品损坏风险。本产品包含敏感电子组件。请勿在本产品附近存放盛有化学或清洁产品的开口容器。储存前必须将抹布或海绵用清水冲洗干净。

注意: 产品损坏风险。仅可使用粘度在1 CPS至20 CPS之间的起泡洗手液。超出该粘度范围的凝胶皂和起泡洗手皂会损坏皂液器, 并失去保修资格。

重要! 您所购产品可能与插图不一致, 但安装步骤是相同的。您所购型号产品的安装尺寸要求, 请参见规格表。

请遵守所有当地的管道工程和电气法规。

注意: 产品损坏风险。仅可使用粘度在1 CPS至20 CPS之间的起泡洗手液。超出该粘度范围的凝胶皂和起泡洗手皂会损坏皂液器, 并失去保修资格。

Tools and Materials

工具与材料

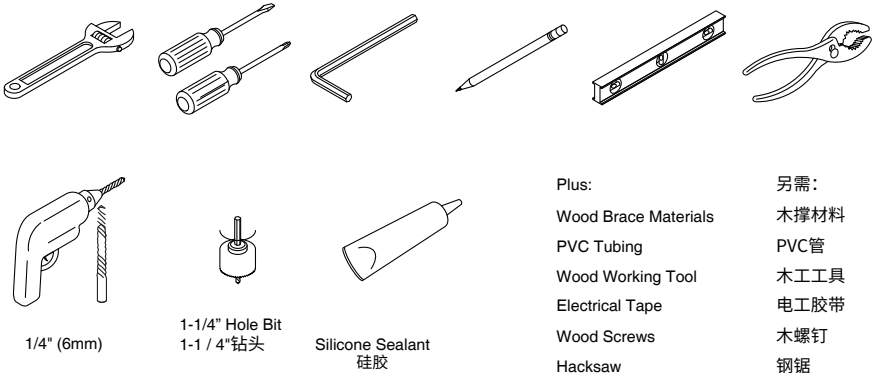

AC(交流)

DC(直流)

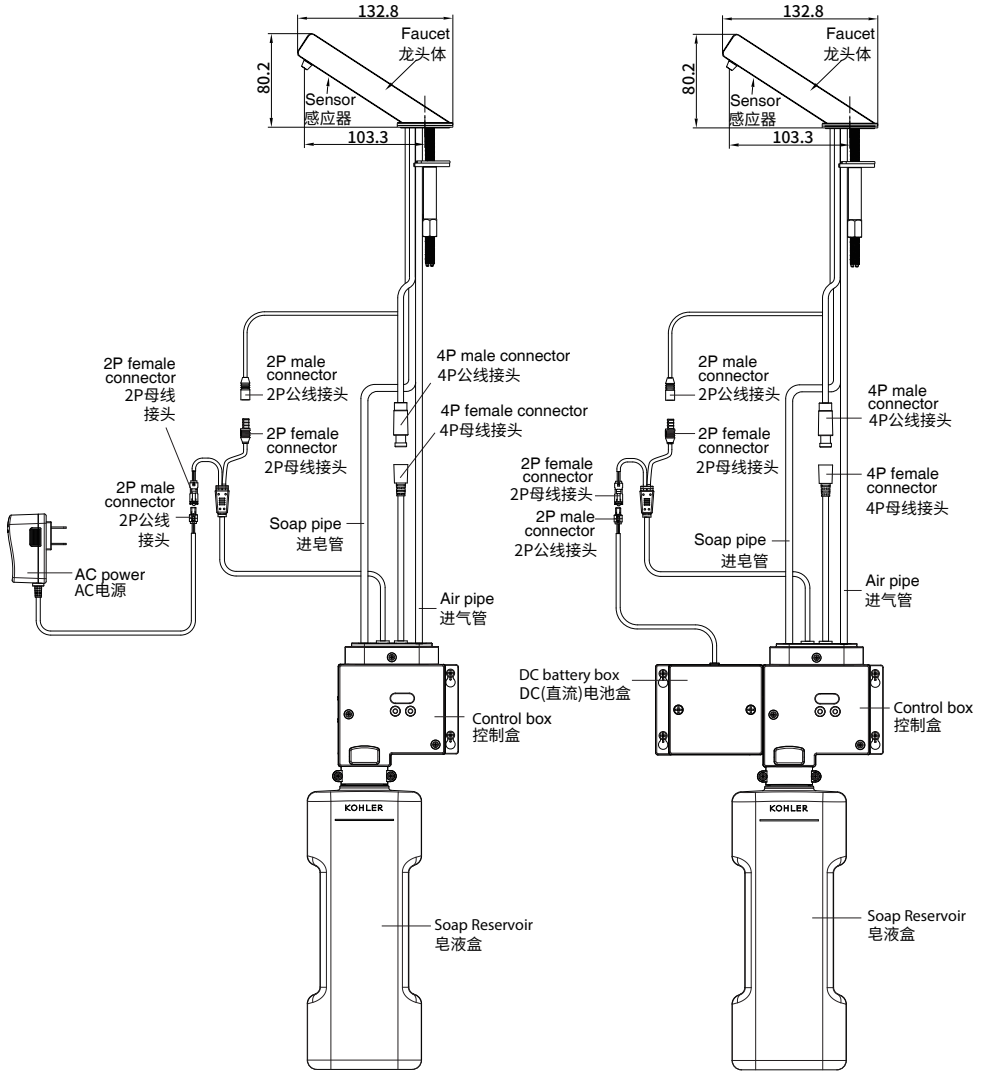

INSTALLATION

安装

Roughing-in

预埋

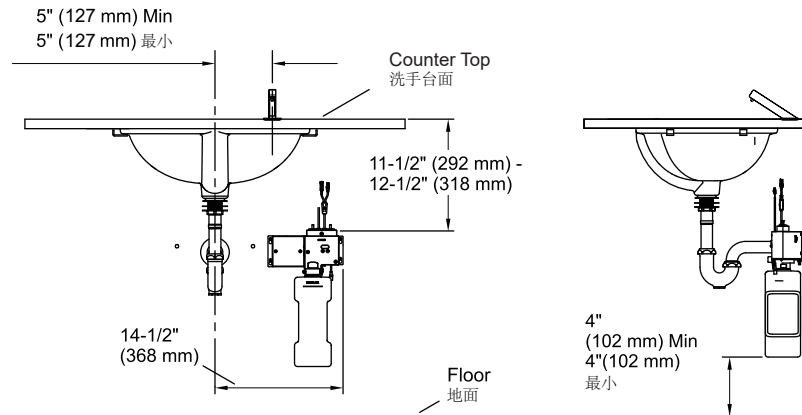

Install the Spout

安装龙头

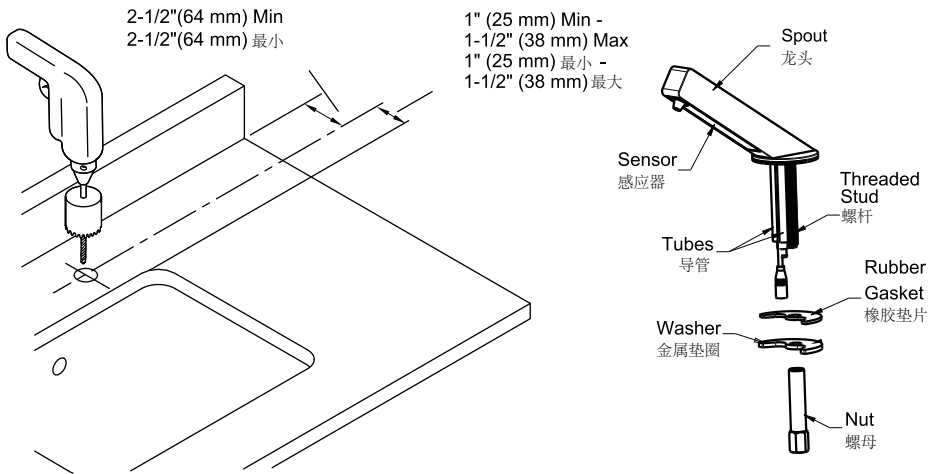

- A 1" (25 mm) minimum to 1-1/4" (32 mm) maximum diameter mounting hole is required.

- Determine the mounting-hole location.

- NOTE: The mounting hardware provided is for a standard deck thickness of 1/4" (6 mm) minimum to 2" (51 mm) maximum. For a deep rough-in installation where deck thickness is 2" (51 mm) minimum to 4-1/2" (114 mm) maximum, order the deep rough-in kit from kohler.com/serviceparts.

- 需要一个直径为1" (25 mm)至1-1/4" (32 mm)的安装孔。

- 确定安装孔的位置。确定安装孔的位置。

- 注意：随机提供的安装零件可用于厚度为1/4" (6 mm)~ 2" (51 mm)的标准台面。当台面厚度为2" (51 mm)~ 4-1/2" (114 mm)且需要进行较深的安装时，可订购加长安装工具包。

INSTALLATION

安装

- A 2-1/2" (64 mm) minimum distance is required between the finished wall and the center of the spout.
- A 1" (25 mm) to minimum to 1-1/2" (38 mm) maximum distance is required between the sink edge and the center of the spout.
- Drill a hole through the mounting surface according to the surface manufacturer's instructions.
- Insert the spout with tubes and wires through the mounting hole.
- From under the sink, slide the rubber gasket and metal washer onto the stud.
- If desired, add silicone sealant to the underside of the escutcheon as needed. Wipe away any excess sealant.
- Thread the nut onto the stud and wrench-tighten to secure the spout to the mounting surface.

- 墙壁与龙头底座中心的最小距离应为2-1/2" (64 mm)。
- 洗手池边缘与龙头底座中心的最小距离应为1" (25 mm) ~ 1-1/2" (38 mm)。
- 按照台面制造商的说明在台面上进行钻孔。
- 将配有导管和导线的龙头插入安装孔。
- 从洗手池底部将橡胶垫片和金属垫圈安在螺柱上。
- 必要时,可在底座下侧施加硅胶。将多余的硅胶擦干净。
- 将螺母拧到螺柱上用扳手拧紧,从而将龙头固定到台面上。

Install the Control Box

安装控制盒

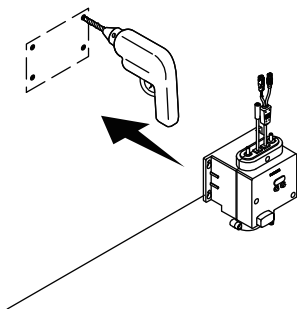

- Mark the location of the mounting holes.
- Attach the control box to the wall as shown.
- Secure with the four screws provided.

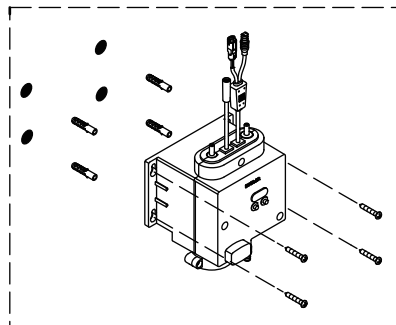

- 标记安装孔的位置。
- 如图所示将控制盒放置在墙壁上。
- 使用随机提供的四个螺钉进行固定。

Install the DC Power Unit

安装直流电源装置

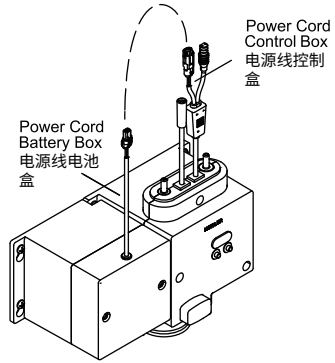
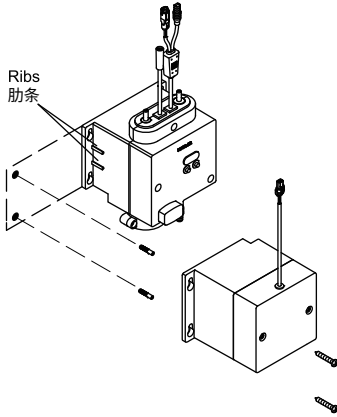

- Unthread the screws from the battery box to remove the battery box cover.

- NOTE: Do not mix used and new batteries.

- Insert four D batteries (provided). Reinstall the battery box cover and secure with the screws.

- Align the grooves on the battery box with the ribs on the side of the control box.

- Mark the location of the mounting holes.

- NOTE: The provided wall anchors are for concrete wall installation. Use the appropriate wall anchors depending on your wall material.

- Drill the holes per the anchor manufacturers instructions. If using the provided wall anchors, drill 1/4" (6 mm) pilot holes.

- Slide the battery box onto the ribs on the side of the control box. Secure with the screws.

- 拧下电池盒上的螺丝，卸下电池盒盖。

- 注意：请勿混用新旧电池。

- 放入四节一号电池（需另购）。重新安装电池盒盖并用螺丝固定。

- 将电池盒上的凹槽与控制盒侧面的肋条对准。

- 标记安装孔的位置。

- 注意：随机提供的膨胀螺丝适用于混凝土墙壁的安装。根据您的墙壁材料选择合适的膨胀螺丝。

- 根据锚固件制造商的说明进行钻孔。如果采用随机提供的膨胀螺丝，需要钻取1/4" (6 mm)的导向孔。

- 将电池盒滑到控制盒侧面的肋条上。使用螺丝固定。

Connect the Control Box Wires

连接控制盒电线

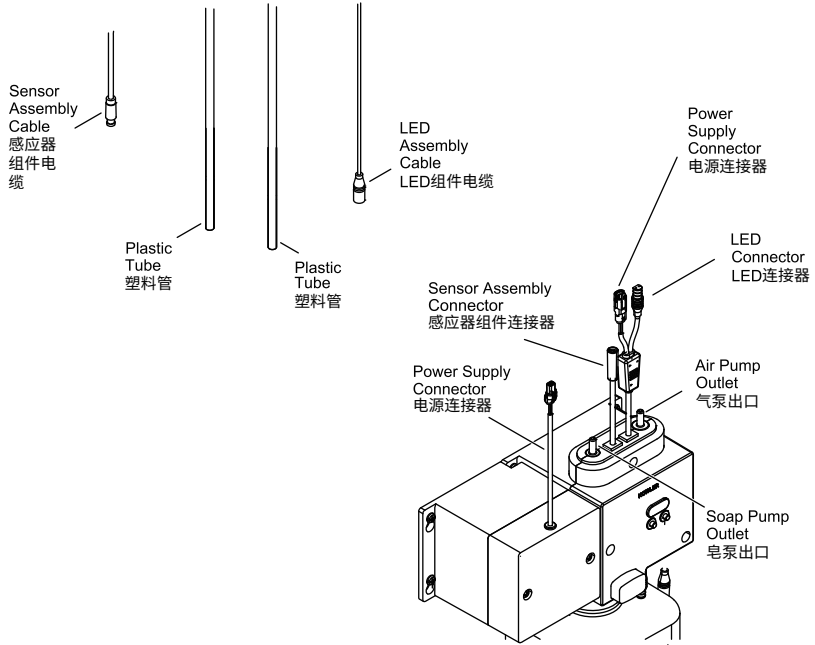

- **IMPORTANT!** Verify that the cables are not pinched when connecting to the control box.

- **IMPORTANT!** The area in front of the sensor must be free of objects during the 2 minute learning cycle or the soap dispenser may not function properly.

- Connect the sensor cable from the spout to the sensor cable from the control box.

- Connect the LED cable from the spout to the LED cable from the control box.

- Connect the power supply connector from the battery box to the power supply connector from the control box.

- Allow 2 minutes for the sensor to cycle through the automatic sensing distance.

- **NOTE:** Once the power supply cords are connected the base of the soap dispenser will lash red twice every six seconds. This is normal and is a signal that there is no soap in the reservoir. After the soap is filled and primed the lashing will stop.

- Secure any extra wire under the counter.

- **重要!** 确保连接至控制盒电缆没有被夹住。

- **重要!** 在2分钟的学习循环内, 感应器前方区域不得有任何物体, 否则皂液器可能无法正常工作。

- 将龙头的感应器电缆与控制盒的感应器电缆相连接。

- 将龙头的LED电缆与控制盒的LED电缆相连接。

- 将电池盒的电源连接器与控制盒的电源连接器相连接。

- 等待2分钟, 让感应器在自动感应距离内循环。

- **注意:** 连接电源线后, 皂液器的底座每六秒钟闪烁两次红光。这属于正常现象, 说明皂液瓶中没有皂液。装满皂液并启动后, 灯光闪烁停止。

- 将多余的电线固定在洗手台下面。

Install the Power

连接电源

AC(交流)

DC(直流)

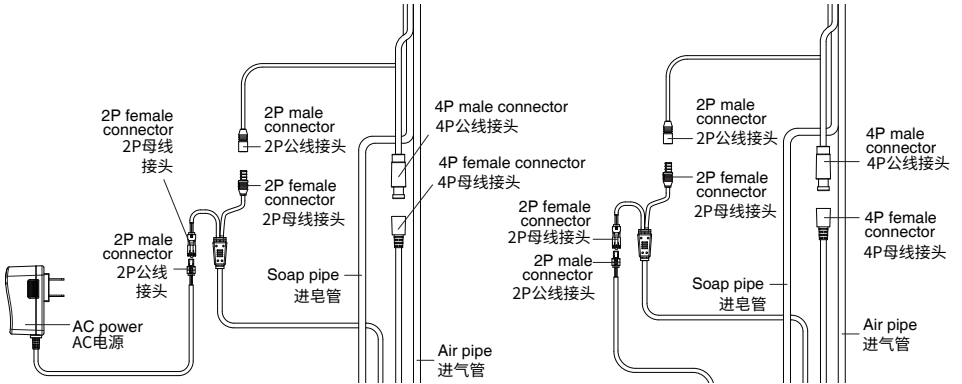

Connect the Tubes

连接导管

- **NOTE:** The plastic tubes are interchangeable. Either tube can be connected to the soap or air pump outlet.

Soap Pump Connections

- Press the plastic tube onto the soap pump outlet on the control box until the tube stops.
- Verify that the tube is secure.

Air Pump Connections

- Press the remaining plastic tube onto the air pump outlet on the control box until the tube stops.
- Verify that the tube is secure.

注意：塑料管是可互换的。任何一根导管均可连接至皂液或气泵出口。

皂液泵的连接

- 将塑料管按压到控制盒上的皂液泵出口上，直至导管中断。
- 确保导管固定牢固。

气泵的连接

- 将剩余的塑料管按压到控制盒上的气泵出口上，直至导管到底。
- 确保导管固定牢固。

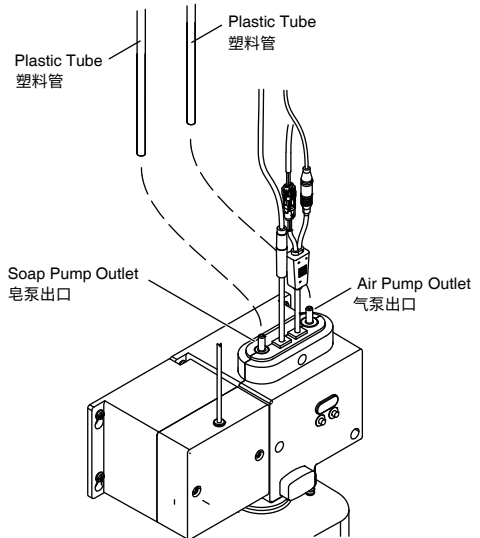

Fill the Soap Reservoir

注满皂液瓶

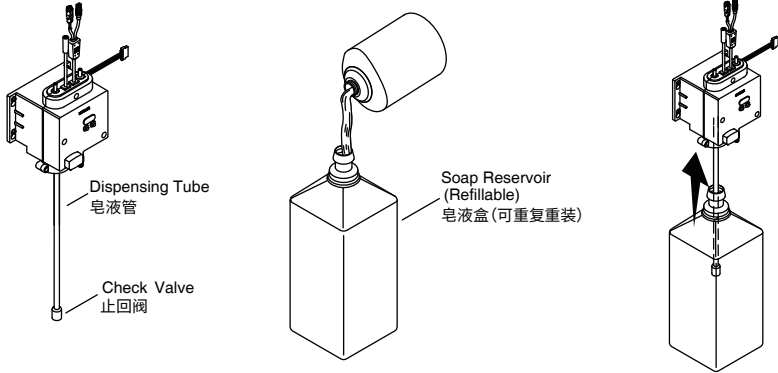

- **IMPORTANT!** Rinse the empty soap reservoir with clean warm water before first use.
- **IMPORTANT!** Use only foaming hand soap. Foaming hand soap must not contain any suspended particles. Do not use liquid hand soap. Using improper soap may void the products warranty.
- Fill the soap reservoir with Kohler foaming hand soap to the "Max Fill" line. Do not overfill the soap reservoir.
- Insert the dispensing tube from the control unit into the soap reservoir.
- Press the soap reservoir into place until an audible click is heard.

- **重要!** 首次使用前, 请用干净的温水冲洗空的皂液盒。

- **重要!** 只能使用泡沫洗手液。泡沫洗手液中不得含有任何悬浮颗粒。请勿使用液体洗手液。使用不当的皂液可能会失去产品保修资格。

- 向皂液盒中注入泡沫洗手液直至达到“最大填充”线。请勿将皂液盒充注得过满。

- 将从控制装置引出的皂液管插入皂液盒。

- 将皂液盒按压到位, 直至听到咔哒一声。

Prepare the Soap Dispenser

准备皂液器

- Press the priming button in the control unit until the soap streams from the spout nozzle – approximately 10 seconds.

- 按压控制装置中的手动出皂按钮直至皂液从喷嘴流出, 大约需要10秒钟。

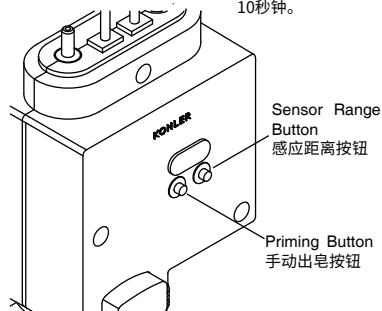

Set the Volume of Soap Dispensed 设置出液量

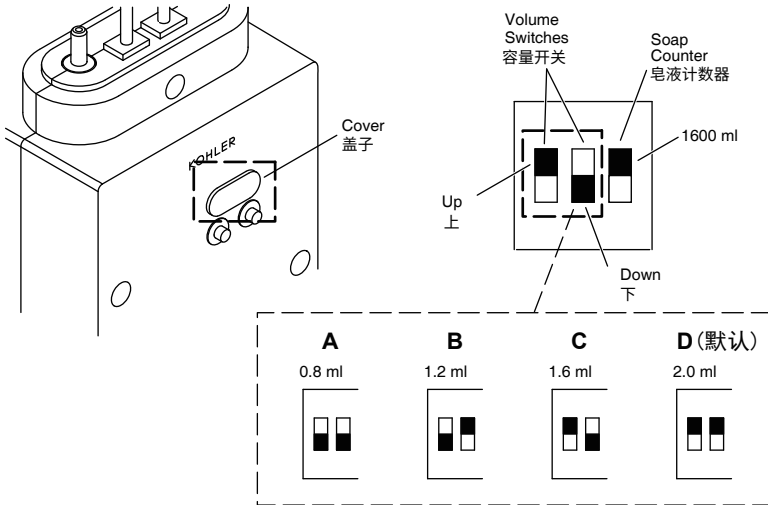

- **IMPORTANT!** Four options are available to control the amount of dispensed soap. The desired option is set by toggling the volume switches to an up or down position.

- **NOTE:** The dispenser comes equipped with a 1600 ml reservoir, and the soap counter is set to the 1600 ml position.

- Lift the rubber cover to access the control switches.

- Set the position of the two volume switches for the desired volume of soap dispensed. Refer to the settings shown above.

- Verify that the soap counter switch is set to the correct position for your reservoir size.

- Refer to the chart below for the number of dispenses available based on the volume setting .

- Reinstall the rubber cover.

- Refer to the chart below for the approximate number of dispenses available based on the volume setting .

- **重要!** 有四个选项可用于控制出液量。可通过将容量开关切换至上或下的位置来设置所需的选项。

- **注意:** 皂液器配有1600ml的皂液盒, 皂液计数器设置在1600ml的位置上。

- 提起橡胶盖以操作控制开关。

- 通过设置两个容量开关的位置来获得所需的出液量。请参考上文所示的设置。

- 确保已根据皂液盒的尺寸将皂液计数器开关设置到正确的位置。

- 皂液盒可选出液次数设置, 请参阅下表。

- 重新安装橡胶盖。

- 皂液盒的大约出液次数设置, 请参阅下表。

Setting	Soap Volume Dispensed	Soap Count (1600 ml)
A	0.8 ml	1800
B	1.2 ml	1200
C	1.6 ml	900
D	2.0 ml	720

设置	出液量	出液次数 (1600ml)
A	0.8 ml	1800
B	1.2 ml	1200
C	1.6 ml	900
D	2.0 ml	720

Set the Sensor Range

设置感应距离

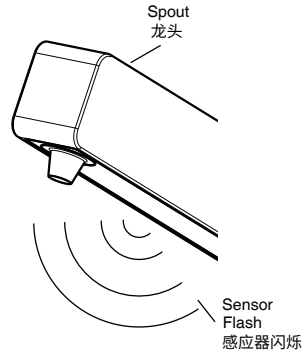
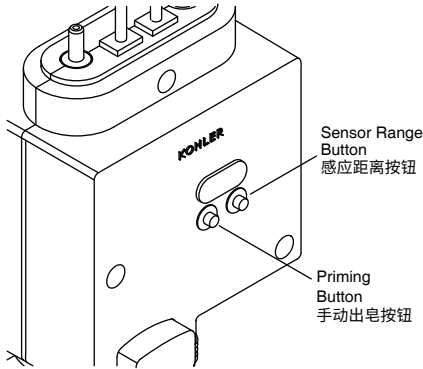

- **NOTE:** The default sensor distance is 2-3/4" (70 mm) +/- 3/8" (10 mm).
- Press and hold the sensor range button for 2 seconds until the sensor flashes red.
- **NOTE:** The sensor range is 1" (25 mm) – 4" (102 mm).
- Hold an object at the desired distance in front of the sensor.

注意：默认感应距离为70 mm ± 10 mm。

按下感应距离按钮并持续2秒钟，直至感应器闪烁红光。

注意：感应距离为1" (25 mm) – 4" (102 mm)。

将物体放在感应器前的目标距离处。

Spout LED Indicators

龙头LED指示灯

Flashing BLUE

The base of the soap dispenser will lash BLUE every 6 seconds when the voltage is lower than 4.8 volts. The soap dispenser will continue to dispense soap.

The base of the soap dispenser will lash (twice) BLUE every 6 seconds when the voltage is lower than 4.5 volts. The soap dispenser will not work. Replace the batteries.

闪烁蓝光

当电压低于4.8V时，皂液器的底座每6秒闪烁一次蓝光，皂液器将继续排出皂液。

当电压低于4.5V时，皂液器的底座每6秒闪烁一次（闪两下）蓝光，皂液器不工作，需更换电池。

Flashing RED

The base of the soap dispenser will lash RED every 6 seconds when the soap is running low. The soap dispenser will continue to dispense soap.

The base of the soap dispenser will lash (twice) RED every 6 seconds when the soap is out. The soap dispenser will not dispense soap. Refill the soap reservoir and re-prime the dispenser.

闪烁红光

当皂液余量较低时，皂液器的底座每6秒闪烁一次红光，皂液器将继续排出皂液。

当皂液用尽时，皂液器的底座每6秒闪烁一次（闪两下）红色，皂液器不出皂液，重新装满皂液盒并重新手动出皂一次启动皂液器。

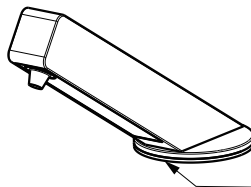

TROUBLESHOOTING

故障排除

Symptoms	Probable Cause	Recommended Action
A red LED light flashes at the base of the soap dispenser once every 6 seconds	The soap is running low (70% of cycle used after priming)	Refill the soap reservoir and prime the soap dispenser with soap
A red LED light flashes at the base of the soap dispenser twice every 6 seconds	The soap is out or very low (90% of cycle used after priming)	Refill the soap reservoir with soap and prime the soap dispenser
A blue LED light flashes at the base of the soap dispenser once every 6 seconds	The battery is running low (lower than 4.8 volts)	Replace the batteries and prime the soap dispenser
A blue LED light flashes at the base of the soap dispenser twice every 6 seconds	The battery is out of power (lower than 4.5 volts)	Replace the batteries and prime the soap dispenser
No soap dispenses	The sensor lens is dirty	Wipe the sensor lens with a clean, dry, soft cloth
	The sensor cable is disconnected	Reconnect the sensor cable
	The tube (soap and air) is disconnected	Reconnect the tube to the control box
	No power supply or wrong connection	Check the power supply connection
	The soap pump is not primed after refilling	Prime the pump
	The dispensing tube/check valve is blocked	Clean the dispensing tube/check valve with warm water
	The dispensing tube/check valve is blocked	Clean the dispensing tube/check valve with warm water
The volume of soap dispensed is small or nonexistent	The nozzle is clogged	Remove the soap nozzle and foaming assembly. Clean with warm water
	The check valve is clogged	Remove the check valve from dispensing tube. Clean with warm water
	The soap pump is not working correctly	Order and install a new soap pump
Only air bubbles are dispensing	The soap pump outlet is clogged	Remove the soap pump tubing
	The soap pump is leaking	Order and install a new soap pump
No foam is dispensing. Only liquid soap is dispensing	The air pump is disconnected	Check the air pump connection and reconnect the tube to the control box
	The air pump/tube is clogged	Remove the air pump tubing. Clean the air pump outlet with warm water
	The air pump is not working	Order and install a new air pump

故障现象	判断分析	解决方法
皂液器底座的红色LED灯每六秒闪烁一次	皂液余量较低(启动后用了一个循环的70%)	用皂液重新装满皂液盒, 并启动皂液器
皂液器底座的红色LED灯每六秒闪烁两次	皂液用尽或极少(启动后用了一个循环的90%)	用皂液重新装满皂液盒, 并启动皂液器
皂液器底座的蓝色LED灯每六秒闪烁一次	电池电量不足(低于4.8V)	更换电池并启动皂液器
皂液器底座的蓝色LED灯每六秒闪烁两次	电池没电(低于4.5V)	更换电池并启动皂液器
不出皂液	感应窗脏了	用干净、干燥的软布擦拭感应窗
	感应器电缆已断开	重新连接感应器电缆
	导管(皂液和空气)已断开	将导管重新连接至控制盒
	没有电源或连接错误	检查电源连接
	重新装满后未启动皂液泵	启动泵
	皂液管/止回阀堵塞	用温水清洁皂液管/止回阀
	感应距离内存在物体	将物体移出感应距离, 等待20秒, 然后再启动皂液器
出流量很小或没有	喷嘴堵塞	拆下喷嘴和发泡组件, 用温水清洗
	止回阀堵塞	从皂液管上卸下止回阀, 用温水清洗
	皂液泵无法正常工作	订购并安装新的皂液泵
只有气泡排出	皂液泵出口堵塞	拆下皂液泵管, 用温水清洗皂液泵的出口
	皂液泵泄漏	订购并安装新的皂液泵
没有泡沫排出, 只有洗手液排出	皂液泵出口堵塞	拆下皂液泵管, 用温水清洗皂液泵的出口
	气泵已断开	检查气泵连接, 将导管重新连接至控制盒
	气泵/导管堵塞	拆下气泵管, 用温水清洗气泵的出口
	气泵不工作	订购并安装新的气泵

Do not use any abrasive or harsh cleaners to clean the faucets.

For best results, keep the following in mind when caring for your KOHLER product:

Always test your cleaning solution on an inconspicuous area before applying to the entire surface. Visit Kohler.com/clean for Kohler faucet cleaner products.

Wipe surfaces clean and rinse completely with water immediately after applying cleaner. Rinse and dry any overspray that lands on nearby surfaces.

Do not allow cleaners to soak on surfaces.

Use a soft, dampened sponge or cloth. Never use an abrasive material such as a brush or scouring pad to clean surfaces.

Upon cleaning other areas of the restroom be sure the sensor lenses are protected from other cleaning chemicals/solvents to prevent potential damages to the sensor and/or electronics.

It is recommended to lush the system with warm water every 2 to 3 months.

- Remove and clean the nozzle foaming assembly with warm water.
- Remove and clean the check valve from the dispensing tube in the soap reservoir with warm water.
- Fill the soap reservoir with minimal amount of clean warm water.
- Re-attach the soap reservoir to the control box. Press the system prime button. Hold the button down until all of the water has been lushed down until all of the water has been lushed
- Refill the soap reservoir with soap. Press the system prime button. Hold down the button until any residual water is pushed through the pump and soap is dispensed.

请勿使用任何擦洗剂或刺激性的清洁剂来清洁水龙头。

为了达到最佳效果, 请您在保养科勒产品时牢记以下几点:

在将清洁溶液用于整个表面之前, 先在不明显的区域进行测试。访问Kohler.com/clean获取科勒水龙头清洁剂产品的信息。

使用清洁剂后立即擦拭表面并用清水彻底冲洗。清洗并擦干落在附近表面上的所有过量喷涂物。

请勿使清洁剂在表面上积聚。

使用柔软的湿海绵或抹布。切勿使用刷子或百洁布等粗糙材料来清洁表面。

清洁洗手间的其他区域时, 确保感应器镜片不会受到其他清洁化学品、溶剂的侵蚀, 避免给感应器和/或电子设备造成潜在损坏。

建议每2至3个月用温水冲洗一次系统。

- 卸下喷嘴发泡组件并用温水清洗。
- 卸下皂液盒中皂液管上的止回阀, 并使用温水进行清洗。
- 用最少量的干净温水充注皂液盒。
- 将皂液盒重新安装到控制盒上。按下系统启动按钮。按住按钮, 直至系统被完全冲洗一遍。
- 将皂液盒注满皂液。按下系统启动按钮。按住按钮, 直至将残留的水推入泵中并排出皂液为止。